

SECTION 5 MAINTENANCE AND SERVICE

TABLE OF CONTENTS

	<u>Page No.</u>
<u>List of figures:</u>	
Figure 5.1-1. Control Module Pin Reference Chart	2
Figure 5.1-2. Hand Held Calibration/Diagnostic Tool Key Functions	6
Figure 5.1-3. Control Module Load Calibration - Code Messages & Definitions	7
Figure 5.1-4. Control Module Load Calibration Procedure	11
<u>List of tables:</u>	
Table 5.1-1. LED Error Codes - Quick Reference	3
Table 5.1-2. LED Error Codes - Code Breakdown	4
Table 5.1-3. Group Codes	15

Refer to Section 5 of the Maintenance & Parts manual for additional information.

Figure 5.1-1. Control Module Pin Reference Chart

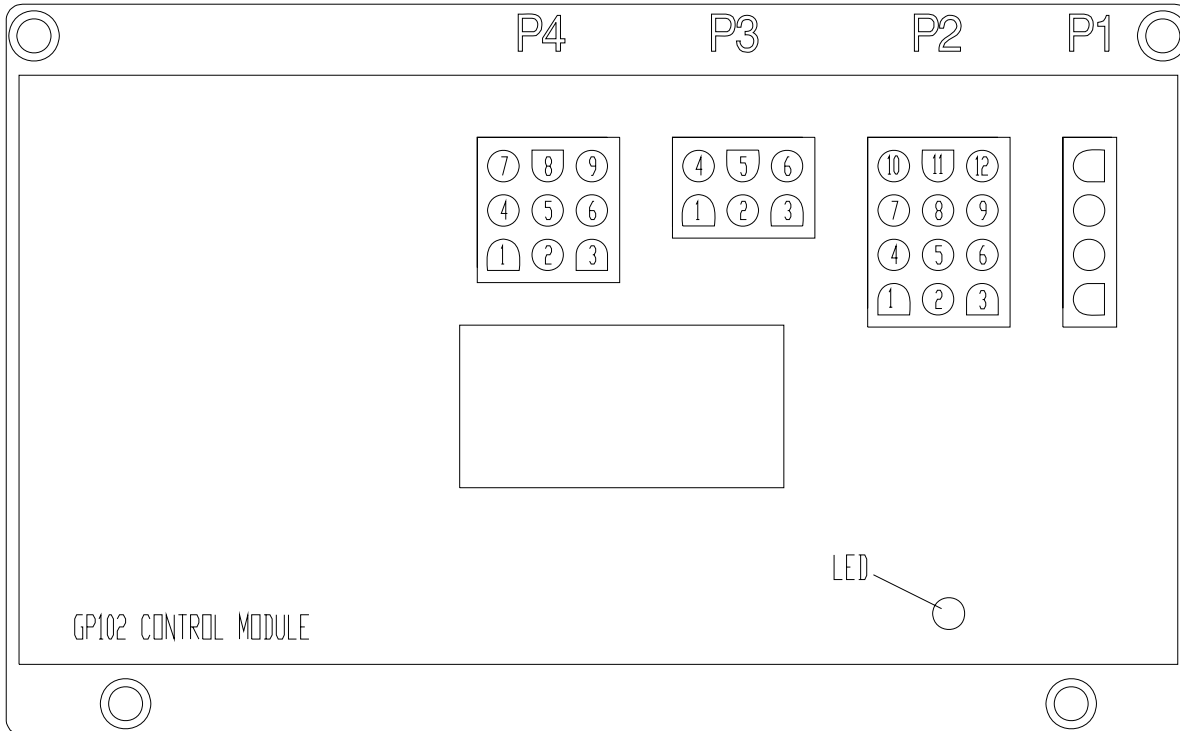

PLUG	PIN #	WIRE # AND COLOUR	WIRE FUNCTION
P1			The Calibration Connection
P2	1	Not Used	Not Used
P2	2	10E Black/White	Input Power From Base Terminal Strip To Confirm Lower Control Is Selected
P2	3	14D Black	Raise Platform Input
P2	4	13D Orange	Lower Platform Input
P2	5	Not Used	Not Used
P2	6	Not Used	Not Used
P2	7	16 White/Black	Forward Direction Input
P2	8	15 Blue	Reverse Direction Input
P2	9	Not Used	Not Used
P2	10	35B Red/Black	Input From LS1 High Speed Limit Switch To Verify ON/OFF Limits
P2	11	02 White	Negative Input From Base Terminal Strip
P2	12	10C Red	Main Power Input From Base Terminal Strip
P3	1	22 Red	Output To FL-22 Flashing Light
P3	2	29 Black	Output To BP-29 Beeper
P3	3	60 Black/White	Output To Overload Warning Light On Control Box
P3	4	28 Green/Black	Output To 28CR1 Tilt Relay And 28CR2 Down Relay
P3	5	02 White	Negative for Flashing Light and Beeper
P3	6	28E Green/White	Output To 28ECR1 Aux. Tilt Relay And 28ECR2 Aux. Down Relay
P4	1	Not Used	Not Used
P4	2	60A Green	Varied Input From Transducer
P4	3	28B Green	Varied Input From Angle Transducer
P4	4	Not Used	Not Used
P4	5	Not Used	Not Used
P4	6	910 Black	Positive Signal To Angle Transducer
P4	7	902 White	Negative Signal To Angle Transducer
P4	8	900 White	Negative Signal To Pressure Transducer
P4	9	910 Black	Positive Signal To Pressure Transducer

60303AD

Table 5.1-1. LED Error Codes - Quick Reference

HELP Message	LED indication
EVERYTHING OK	Steady on
IN GROUND MODE!	Steady on
OVERLOAD FUNCTIONS DISABLED!	6/6
VEHICLE TILTED	1/1
VEHICLE OVERLOADED	1/2
WAITING FOR B+ ON P2-12	5/2
ARMGUARD ACTIVE!	1/3
TOO HIGH - DRIVE PREVENTED	1/4
TOO HIGH - LIFT UP PREVENTED	1/5
TESTING HWFS	7/8
IDLE TIMEOUT ACTIVE!	Always off
WAITING FOR NEUTRAL	5/5
ELEVATION SWITCH SHIFTED?	2/1
ELEVATION SWITCH STUCK?	2/2
NO LAST CALDATE!	6/3
LOAD NOT CALIBRATED	6/2
DRIVE/LIFT INPUTS FAULTY!	5/6
UP/DOWN SELECT INPUTS ACTIVE TOGETHER	5/4
INVALID LOAD - CHECK SENSORS	6/4
HEIGHT NOT CALIBRATED	6/1
INVALID HEIGHT - CHECK SENSOR	6/5
EMS INPUTS FAULTY!	5/2
B+ SUPPLY TOO LOW	5/1
P4-1 OR P5-1 SHORT TO 0V?	4/1
P3-4 SHORT TO SUPPLY!	4/2
P3-4 SHORT TO 0V?	4/3
P3-4 SHORT TO SUPPLY?	4/4
P3-6 SHORT TO 0V?	4/5
P3-6 SHORT TO SUPPLY?	4/6
FAULT: BAD TILT SENSOR	7/1
FAULT: BAD HWFS	7/2
FAULT: BAD SLAVE ANALOGS	7/3
FAULT: BAD STRAIN MONITORS	7/4
FAULT: BAD SLAVE MICRO	7/5
FAULT: HWFS STALLED!	7/6
STARTUP!	7/7
FACTORY OVERRIDE	6/7

60405AA

Reading the Codes:

In order to read the fault codes, a sequence of pauses and flashes can be seen on the LED mounted on the GP102 module. The codes are continuously displayed by the LED until the fault is cleared, the GP102 reset and no longer detects the fault, or idle timeout becomes active.

The sequence is as follows:

1. Quarter second flashes followed by quarter second pauses indicate the first digit.
2. A 1.5 second pause.
3. Quarter second flashes followed by quarter second pauses indicate the second digit
4. A 4 second pause. Repeat steps 1-4

Since the GP102 only reports one error, only one code can be read from the LED per instance. If the error is cleared and another error is present, it will then be presented.

Table 5.1-2. LED Error Codes - Code Breakdown

Diagnostic sequence dependant on LED flash code:

NO LAST CALDATE!	63
LOAD NOT CALIBRATED	62
HEIGHT NOT CALIBRATED	61

An EZcal is required!

WAITING FOR NEUTRAL	55
DRIVE/LIFT INPUTS FAULTY!	56
UP/DOWN SELECT INPUTS ACTIVE TOGETHER	54
EMS INPUTS FAULTY!	52

Check inputs on P2 pins 1, 2, 3, 4, 5, 6, 7, 8.

P3-4 SHORT TO SUPPLY!	42
P3-4 SHORT TO SUPPLY?	44
P3-6 SHORT TO SUPPLY?	46

Disconnect plug P3. If fault clears there is a problem with the wiring from P3-4 or P3-6 to the rest of the vehicle.

ARMGUARD ACTIVE!	23
ELEVATION SWITCH SHIFTED?	21
ELEVATION SWITCH STUCK?	22

If the 23 flash code is triggered by armguard, it will occur once then clear. This is not a true fault but just an indication of the reason for the vehicle stop.

If the 21 or 22 flash code is triggered by a fault with the elevation switch, it will not clear. Check that the elevation switch correctly opens/closes when the platform is raised/lowered.

P3-4 SHORT TO 0V?	43
P3-6 SHORT TO 0V?	45

Disconnect plug P3. If fault clears there is a wiring fault from P3-4 or P3-6 to the rest of the vehicle.

INVALID LOAD – CHECK SENSORS	64
------------------------------	----

Check the voltage out of the pressure transducer, into P4-2. It should be between 0.5V (zero pressure) and 4.5V (maximum pressure) and should vary as the platform load & position varies.

WAITING FOR B+ ON P2-12	52
B+ SUPPLY TOO LOW	51
P4-1 OR P5-1 SHORT TO 0V?	41

Check that the battery voltage is not too low.

Verify battery voltage on P2-12.

Disconnect plug P4 – if the fault clears there is a wiring fault from P4-1 to the rest of the vehicle.

Table 5.1-2. LED Error Codes - Code Breakdown

VEHICLE TILTED	11
VEHICLE OVERLOADED	12
TOO HIGH – DRIVE PREVENTED	14
TOO HIGH – LIFT UP PREVENTED	15

These are not true faults but an indication that vehicle movement is prevented.
 Remove excessive load from the platform.
 Lower the platform if close to maximum height.
 Move the vehicle to level ground.

INVALID HEIGHT - CHECK SENSOR	65
-------------------------------	----

Check the voltage out of the height transducer, into P4-3. It should be between .4V and 4.6V and should vary as the platform position varies.

TESTING HWFS	78
STARTUP!	77

These are not true faults unless they do not clear – the start-up tests should only occur for a short time.

OVERLOAD FUNCTIONS DISABLED!	66
FACTORY OVERRIDE	67

These are not true faults – the GP102 has been configured to suppress overload functionality.

IDLE TIMEOUT ACTIVE!	Always OFF
FAULT: BAD TILT SENSOR	71
FAULT: BAD HWFS	72
FAULT: BAD SLAVE ANALOGS	73
FAULT: BAD STRAIN MONITORS	74
FAULT: BAD SLAVE MICRO	75
FAULT: HWFS STALLED!	76

Action a function to clear the idle timeout if it occurred.
 Ensure the GP102 is correctly mounted – incorrect mounting can cause the “bad tilt sensor” diagnostic to occur. Otherwise there may be an internal problem with the GP102.

Figure 5.1-2. Hand Held Calibration/Diagnostic Tool Key Functions

 **WARNING**

Only trained and authorized personnel shall be permitted to service an aerial platform.

 **WARNING**

Read all instructions closely before attempting each phase of the calibration procedure.

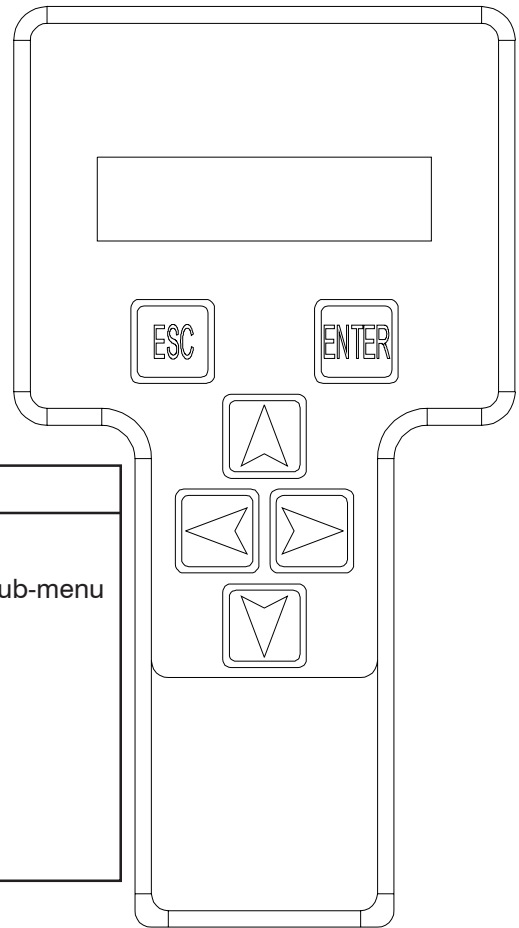







SYMBOL	KEY FUNCTIONS
 	<p>ESC/ENTER BUTTONS To move back and forth between menu and sub-menu</p>
 	<p>LEFT/RIGHT BUTTONS Select menus and setting to be adjusted</p>
 	<p>UP/DOWN BUTTONS Adjust setting values</p>

Figure 5-1-3. Control Module Load Calibration - Code Messages & Definitions

During calibration the following FAILURE messages may appear:

F01:CHECK HWFS	This message is given if the GP102 startup tests have not completed.Check HELP message for more information.
F02:NOT GROUND MODE	This message is given if the machine is not in ground mode (P2-2 must be high).Calibration can only be carried out in ground mode.
F03:NOT STOPPED	This message is given if any function switch is closed.Check DIAGNOSTICS / SWITCHES to see which function switch is closed.
F04:TILTED	This message is given if the machine is tilted.Calibration must be carried out with the machine level.If the machine is level, use the SETUPS / TILT SETUPS to set the GP102 level.
F05:BAD HEIGHT	This message is given if the height sensor output (P4-3) is out of range at the start of calibration.The height sensor output must be between 0.9V and 4.1V. Check DIAGNOSTICS / SENSORS to see the output. A reading of 0V or 5V is probably due to a wiring problem.
F06:CHECK ELEV	This message is given if the elevation switch (P210) is open at the start of calibration, when the operator has confirmed the “PLATFORM DOWN?” question.If the platform is down, check the elevation switch wiring.
F08:CHECK ELEV	This message is given if the elevation switch (P2-10) is closed at the end of calibration, when the platform should be fully raised.This message would occur if the UP switch was accidentally opened near the start of the lift.If the platform is fully raised, check the elevation switch wiring.
F09:BAD HEIGHT	This message is given if the height sensor output (P4-3) is out of range at the start of calibration.The height sensor output must be between 0.9V and 4.1V. Check DIAGNOSTICS / SENSORS to see the output.
F10:BAD HEIGHT	This message is given if the height sensor output (P4-3) is out of range at the end of calibration.The height sensor output must be between 0.9V and 4.1V. Check DIAGNOSTICS / SENSORS to see the output. A reading of 0V or 5V is probably due to a wiring problem.
F11:NOT UP	This message occurs at the start of calibration if the operator selects a function other than UP.
F13:LOW HEIGHT RANGE	This message occurs at the end of calibration if the height sensor output did not change sufficiently to give a reasonably accurate platform height estimate.DIAGNOSTICS / SENSORS can be used to check the height sensor output (P43) when the platform is fully lowered and fully raised; a difference of at least 1V is to be expected.This message could occur if the UP switch was accidentally opened too early (when the platform is not fully raised).
F15:CHECK ELEV	This message is given if the elevation switch (P2-10) is open when the platform has been fully lowered at the end of calibration.This message would occur if the DOWN switch was accidentally opened before the platform was fully lowered.If the platform is fully lowered, check the elevation switch.

Figure 5-1-3. Control Module Load Calibration - Code Messages & Definitions

F16:LOW ELEV.OPEN	This message is given if the elevation switch (P2 10) opened during lift at a too low height (below 5%).Check CALIBRATIONS / HEIGHT CALS; the “ElevUp” value shows the recorded height where the switch opened.
F17:HIGH ELEV.OPEN	This message is given if the elevation switch (P210) opened during lift at a too high height (above 25%).Check CALIBRATIONS / HEIGHT CALS; the “ElevUp” value shows the recorded height where the switch opened.
F18:LOW ELEV.CLOSE	This message is given if the elevation switch (P210) closed during lower at a too low height (below 5%).Check CALIBRATIONS / HEIGHT CALS; the “ElevDown” value shows the recorded height where the switch opened.
F19:HIGH ELEV.CLOSE	This message is given if the elevation switch (P210) closed during lower at a too high height (above 25%).Check CALIBRATIONS / HEIGHT CALS; the “ElevUp” value shows the recorded height where the switch opened.
F20:HEIGHT <>0%	This message occurs if the platform height is not 0% after the platform has been fully lowered at the end of calibration.The platform must return to the same height each time it is fully lowered.Check DIAGNOSTICS / SYSTEM to check the height.
F28:BAD HEIGHT	This message indicates a problem with the height sensor output (P43) during calibration. The height sensor output must be between 0.9V and 4.1V during calibration and between 0.4v and 4.6v during normal operation. Check DIAGNOSTICS / SENSORS to see the output. A reading of 0V or 5V is probably due to a wiring problem.
F42:LOW PRESSURE	This message indicates that the pressure is too low (0.5V or less) when the elevation switch opens during calibration.Check DIAGNOSTICS / SENSORS to check the pressure.
F43:HIGH PRESSURE	This message indicates that the pressure is too high (4.5V or more) when the elevation switch opens during calibration.Check DIAGNOSTICS / SENSORS to check the pressure.
F44:LOW PRESSURE	This message indicates that the pressure is too low (0.5V or less) at a measurement point.Check DIAGNOSTICS / SENSORS to check the pressure.
F45:HIGH PRESSURE	This message indicates that the pressure is too high (4.5V or more) at a measurement point.Check DIAGNOSTICS / SENSORS to check the pressure.
F46:CHECK ELEV	This message indicates that the elevation switch opened more than once during calibration lifting.
F47:CHECK ELEV	This message indicates that the elevation switch closed more than once during calibration lowering.
F48:BAD PRESSURE	This message is given if the pressure sensor output (P4-2) is out of range at the start of calibration. The height sensor output must be between 0.5V and 4.5V. Check DIAGNOSTICS / SENSORS to see the output. A reading of 0V or 5V is probably due to a wiring problem.

Figure 5-1-3. Control Module Load Calibration - Code Messages & Definitions

F52:TOO FEW!	This message indicates that not enough measurements were recorded during calibration lifting or lowering.
F98: OUT OF RANGE	This message indicates that the “fine tune” calibration is unacceptable.This probably is due to the wrong load being in the platform (ie: specifying “EMPTY” if the platform is loaded, or the other way round) or (Having the incorrect pressure transducer installed).
<u>During calibration the following INFORMATION messages may appear:</u>	
CALDATE:	This message is prompting for the date to be entered; it is stored to identify when the machine was calibrated.The last calibrate date can be viewed in DIAGNOSTICS / LOG.Press LEFT & RIGHT to select the flashing digits.Press UP & DOWN to change the flashing digits.Press ENTER when the entry is complete.IMPORTANT: The date 00/00/00 is not allowed!
FINISHED	This message confirms that calibration is complete and successful.
LIFT EMPTY	This message is displayed while the platform is being raised to the next measurement height, when an EMPTY platform is being calibrated.
LIFT LOADED	This message is displayed while the platform is being raised to the next measurement height, when a LOADED platform is being calibrated.
LIFTING	This message is displayed while the platform is being raised, during HEIGHT-only calibration.
LOWER EMPTY	This message is displayed while the platform is being lowered to the next measurement height, when an EMPTY platform is being calibrated.
LOWER LOADED	This message is displayed while the platform is being lowered to the next measurement height, when an EMPTY platform is being calibrated.
LOWERING	This message is displayed while the platform is being lowered, during HEIGHT-only calibration.
MEASURING #	This message is displayed when the platform is stopped during calibration, when the GP102 takes a measurement.There will be a short delay while the machine is allowed to stabilize after movement is stopped.
MUST GO DOWN!	This message occurs if the wrong switch is closed when the GP102 is waiting for the platform to be lowered.
MUST GO UP!	This message occurs if the wrong switch is closed when the GP102 is waiting for the platform to be raised.
PLATFORM DOWN?	This message is prompting for confirmation that the platform is fully lowered. If necessary the DOWN switch can be activated to lower the platform.Press ENTER to confirm when the platform is fully lowered.
PLATFORM EMPTY?	This message is prompting for confirmation that the platform is completely empty.Press ENTER to confirm if the platform is empty.

Figure 5-1-3. Control Module Load Calibration - Code Messages & Definitions

PLATFORM LOADED?	This message is prompting for confirmation that the platform is loaded to rated load. Press ENTER to confirm if the platform is loaded.
PLEASE LIFT	This message is prompting for the platform to be raised. The UP switch should be closed.
PLEASE LOWER	This message is prompting for the platform to be lowered. The DOWN switch should be closed.
PLEASE WAIT	This message indicates that the GP102 is busy; the delay will be short (no more than 5s).
TOTAL DATA:	This message is displayed at the end of each phase, to confirm the number of measurements recorded by the GP102.

Figure 5-1-4. Control Module Load Calibration Procedure

1. Move the aerial platform to a test area where the platform can be elevated to its maximum working height and reach.
2. Ensure the aerial platform is parked on a firm, level surface.

IMPORTANT

Each phase must be completed before the next phase can be carried out.
All phases must be completed before the aerial platform can be operated.

IMPORTANT

Always follow the instructions of the Calibration instrument.

IMPORTANT

Make sure the aerial platform is on BASE mode.

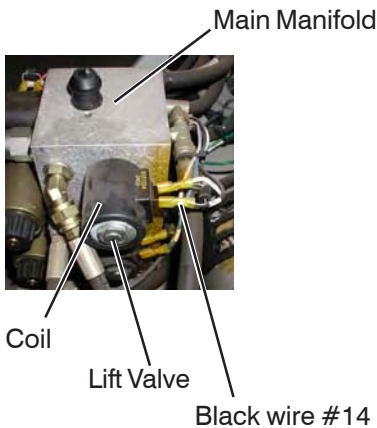

3. Locate the main manifold inside the hydraulic/electric tray.
4. Disconnect the black wire #14 from the lift coil.
5. Locate the contactor on the electrical panel assembly.
6. The jumper connection must be connected between the contactor (wire #19B) and the lift coil (instead of the black wire #14).

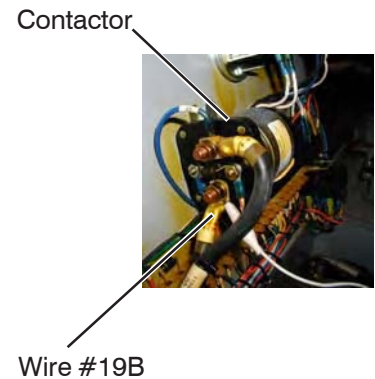

Note

To ensure a good and clear contact, clean the wire terminals before attaching the jumper clip.

JUMPER, Insulated Alligator Clip

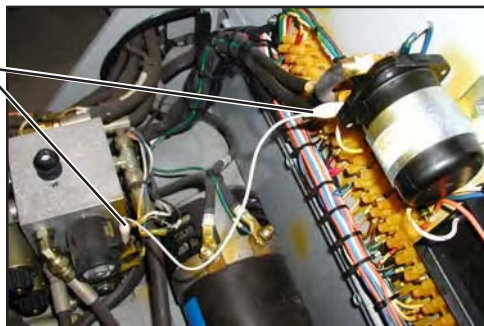

Figure 5-1-4. Control Module Load Calibration Procedure

7. Connect the Easy-Cal tool to the P1 connector on the CONTROL MODULE.
8. The display will show **“Help: Press Enter”**.
By using Left/Right buttons, select the **“Access Level (?)”** from the menu and press the **ENTER** button.

**Contact SKYJACK SERVICE DEPARTMENT At
(44) 1691-676 236 for your Access Level Code Number.**
9. The display will show **“Access Level Code (xxxx)”**.
By using the Up/Down buttons, enter the Access Level Code (xxxx) followed by pressing the **ENTER** button.
10. The display will show **“Access Level 2”**.
By using Left/Right buttons, select the **“Setups”** from the menu and press the **ENTER** button.
11. The display will show **“Machine Defaults”**.
Select the **“Machine Defaults”** from the menu and press the **ENTER** button.
12. The display will show **“Defaults, 0 = Custom”**.
By using Left/Right buttons, select the **“X = Group Code”** from the menu and press the **ENTER** button.
13. The display will show **“X=GROUP CODE”**. *(For group Code Refer to Table 5.1-3)*
By using the Up/Down buttons, enter the **“Group Code (?)”** then by using Left/Right buttons, select the **“Curve”** from the menu.
14. The display will show **“X=CURVE”**. *(For Curve Code Refer to Table 5.1-3)*
By using the Up/Down buttons, enter the **“Curve Code (?)”** followed by pressing the **ESCAPE** button.
15. The display will show **“Machine Defaults”**.
By using Left/Right buttons, select the **“Tilt Setups”** from the menu and press the **ENTER** button.
16. The display will show **“Tilt Setups: Calibrate Level”**.
Select the **“Tilt Setups: Calibrate Level”** from the menu and press the **ENTER** button.
17. The display will show **“Calibrate Level: Yes: Enter, No: ESC”**.
Select the **“Yes”** from the menu by press the **ENTER** button.
18. The display will show **“Calibrate Level: Tilt 0.0’ , 0.0”**.
Select the **“ESCAPE”** from the menu once.
19. The display will show **“Tilt Setups Calibrate Level”**.
Select the **“ESCAPE”** from the menu once again.
20. The display will show **“Setups Tilt Setups”**.
By using Left/Right buttons, select the **“Load Setups”** from the menu and press the **ENTER** button.
21. The display will show **“Load Setups: Calibrate Load”**.
Select the **“Load Setups: Calibrate Load”** from the menu and press the **ENTER** button.
22. At this point, elevate the aerial platform at full height, check the harness and making sure it is not stretched tight, then lower down the platform.
23. The display will show **“Calibrate Load: Platform Down?”**.
Asking for confirmation that the platform is fully lowered?
Check that the platform is fully lowered then press the **ENTER** button to confirm.

Figure 5-1-4. Control Module Load Calibration Procedure

24. The display will show **“Calibrate: Loaded Empty? No”**.
Asking for confirmation that the platform is empty?
Check that the platform is empty?
25. By using the Up/Down buttons, enter the **“Yes”** followed by pressing the **ENTER** button.
26. The display will show **“Calibrate Load: Please Lift . . .”**.
Waiting for the lift switch to be activated.
27. Hold the lift switch and keep holding it until the platform is fully elevated.

IMPORTANT

If the lift switch is released earlier than full-height position, the calibration will have to be aborted and repeated from the beginning!

28. When the system detects the lift switch closed, the display will show **“Calibrate Load: Lift Empty”**.
29. After a delay, the system will stop the platform lifting and will take height & pressure measurements; the display will show **“MEASURING # xx”** When the measurements have been taken, the platform will resume lifting.

Note

The lifting ... stopping ... measuring ... lifting process will continue until the platform reaches full height.

30. When the platform reaches full height release the lift switch.
31. The display will briefly show **“TOTAL DATA: 04”** to indicate the number of measurements taken.
32. The display will show **“Calibrate Load: Please Lower . . .”**.

IMPORTANT

If the lower switch is released earlier than full-lowered position, the calibration will have to be aborted and repeated from the beginning!

33. Hold the lower switch and keep holding it until the platform is fully lowered.
34. When the system detects the lower switch closed, the display will show **“Calibrate Load: Lower Empty”**.
35. After a delay, the system will stop the platform lowering and will take height & pressure measurements; the display will show **“MEASURING #xx”** When the measurements have been taken, the platform will resume lowering.

Figure 5-1-4. Control Module Load Calibration Procedure

Note

The lowering ... stopping ... measuring ... lowering process will continue until the platform is fully lowered.

36. When the platform is fully lowered (and height 0% is displayed), release the lower switch.
37. The display will show briefly **“TOTAL DATA: 04”** to indicate the number of measurements taken.
38. The display will show **“Calibrate Load: Caldate: mm/dd/yy”**.
It is recommended that the current date be entered here to provide easy tracking of the date of last calibration. The current date must be entered using the LEFT/RIGHT and UP/DOWN buttons.
39. Press **ENTER** to complete date entry (the system will store it).
40. The display will show **“FINISHED!”**
41. Press the ESC button to exit the **“CALIBRATE LOAD”** option.
42. Remove the jumper wire and re-connect the black wire #14 to the coil removed earlier.
43. Close the hydraulic/electric tray.

NOTE: Continuing partially complete load calibration:

Once a calibration phase has been successfully completed, it is not required to do it again (unless of course a change to the vehicle such as a replacement sensor requires that calibration be repeated). This is useful if the calibration procedure is interrupted – the remaining phases can be completed at a later time.

If a calibration phase has been successfully completed, a “REDO” message is displayed:

REDO DYNAMIC: NO

REDO LOADED: NO

REDO EMPTY: NO

If the phase does not need to be repeated, just press ENTER to move on.

If the phase *does* need to be repeated, press UP or DOWN to change “NO” to “YES” then press ENTER.

Table 5.1-3. Group Codes

Model	Number of Extension Decks	Curve Code	Group Code
3220M	1 Manual Extension Deck	3	3
3220M	1 Powered Extension Deck	4	3
3226M	1 Manual Extension Deck	5	3

60404AB