

Section 3

System Component Identification And Schematics

Table Of Contents

Symbols & Charts

Figure 3.1-1.	Relay Function Chart	3
Figure 3.1-2.	Electrical Symbol Chart	4
Figure 3.1-3.	Hydraulic Symbol Chart.....	5

Hydraulic System

Figure 3.2-1.	Hydraulic Schematic Part List	6
Figure 3.2-2.	Hydraulic Schematic (Model 3220M)	7
Figure 3.2-3.	Hydraulic Schematic (Model 3226M)	8

Electrical Diagrams And Schematics

Figure 3.3-1.	Electrical Schematic And Diagram Parts List	9
Figure 3.3-2.	Control Module to Transducers Diagram	10

Operator's Control Box Diagram

Figure 3.3-3.	Control Box Wiring Diagram (No Rollout Limit) (Model 3220M)	11
Figure 3.3-4.	Control Box Wiring Diagram (Model 3220M, 3226M)	12
Figure 3.3-5.	Control Box Wiring Diagram (Model 3226M)	13

Electrical Panel Diagram

Figure 3.4-1.	Electrical Panel Diagram (Model 3220M/3226M)	15
---------------	--	----

Electrical Schematic

Figure 3.5-1.	Electrical Schematic (Model 3220M/3226M)	16
---------------	--	----



Figure 3.1-1. Relay Function Chart

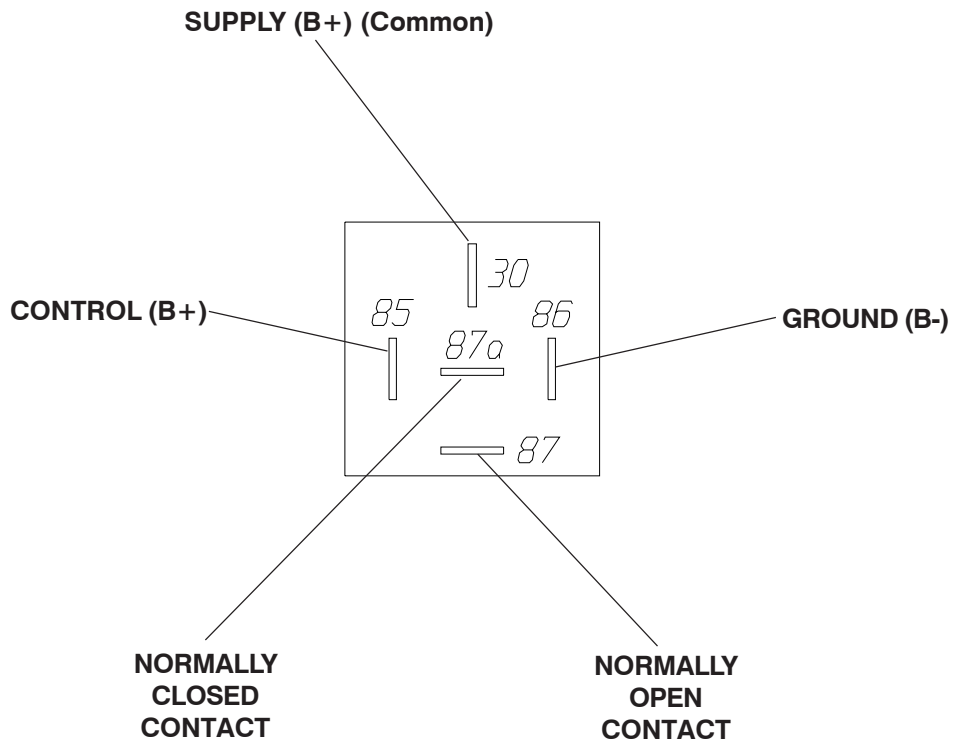

RELAY NO.	RELAY FUNCTION
17CR	BRAKE/STEERING RELAY
17CCR	CUSHION RELAY (MODEL 3215/3219)
17CR1	BRAKE RELAY (MODEL 3215/3219)
21ACR	PROPORTIONAL RELAY
28ACR	PROPORTIONAL RELAY
28CR1	TILT RELAY
28CR2	DOWN RELAY
28ECR1	AUXILIARY TILT
28ECR2	AUXILIARY DOWN

60045AB

Figure 3.1-2. Electrical Symbol Chart























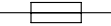







	WIRE CROSSING		HOURMETER		KEY SWITCH
	WIRES JOINED		LIGHT		FOOT SWITCH
	BATTERY		HYDRAULIC VALVE COIL		TOGGLE SWITCH
	GROUND		PROPORTIONAL HYDRAULIC VALVE COIL		PUSH BUTTON
	FUSE		ELECTRIC MOTOR		ROTARY SWITCH
	CIRCUIT BREAKER		HORN		LIMIT SWITCH
	BATTERY CHARGE INDICATOR		EMERGENCY STOP BUTTON		CAM OPERATED LIMIT SWITCH
	CAPACITOR		RESISTOR		TILT SWITCH
	POTENTIOMETER		LEVEL SENSOR		SINGLE POLE SINGLE THROW RELAY
	SINGLE POLE DOUBLE THROW RELAY		DOUBLE POLE SINGLE THROW RELAY		DOUBLE POLE DOUBLE THROW RELAY
	TRIPLE POLE DOUBLE THROW RELAY		DIODE		TRANSISTOR
	ANGLE TRANSDUCER		PRESSURE TRANSDUCER		

Figure 3.1-3. Hydraulic Symbol Chart



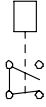
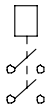
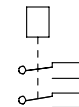
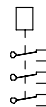

















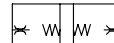







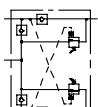



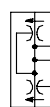



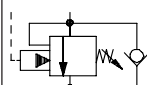

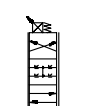
	LINE CROSSING		VARIABLE DISPLACEMENT PUMP		SHUTTLE VALVE		VELOCITY FUSE
	LINE JOINED		HAND PUMP		ACCUMULATOR, GAS CHARGED		SINGLE ACTING CYLINDER
	HYDRAULIC TANK		RELIEF VALVE		CUSHION CYLINDER		DOUBLE ACTING CYLINDER
	HYDRAULIC FILTER WITH BYPASS		PRESSURE REDUCING VALVE		PRESSURE SWITCH		DOUBLE ACTING DOUBLE RODDED
	ELECTRIC MOTOR		FIXED ORIFICE		MOTION CONTROL VALVE		SPRING APPLIED HYDRAULIC RELEASED BRAKE
	ENGINE		ADJUSTABLE FLOW CONTROL		FLOW DIVIDER COMBINER		BRAKE CYLINDER
	FIXED DISPLACEMENT PUMP		CHECK VALVE		COUNTER BALANCE VALVE		ROTARY ACTUATOR
	THREE POSITION FOUR WAY PROPORTIONAL		OIL COOLER		VALVE COIL		BI DIRECTIONAL HYDRAULIC MOTOR
	SERIES PARALLEL HYDRAULIC MOTOR		TWO POSITION TWO WAY NORMALLY CLOSED		TWO POSITION THREE WAY		THREE POSITION FOUR WAY CLOSED CENTER OPEN PORT
	TWO POSITION TWO WAY NORMALLY OPEN		TWO POSITION THREE WAY		THREE POSITION FOUR WAY CLOSED CENTER CLOSED PORT		THREE POSITION FOUR WAY PROPORTIONAL
	PRESSURE TRANSDUCER						

Figure 3.2-1. Hydraulic Schematic Parts List

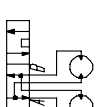
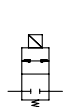
Index No.	Skyjack Part No.	Qty.	Description
PT1	134431	1	TRANSDUCER, Pressure 2000 psi (Model 3220M/3226M)
	134532	1	TRANSDUCER, Pressure 1250 psi (Model 3226M)

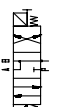
Figure 3.2-3. Hydraulic Schematic (Model 3226M)

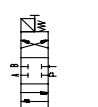
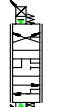

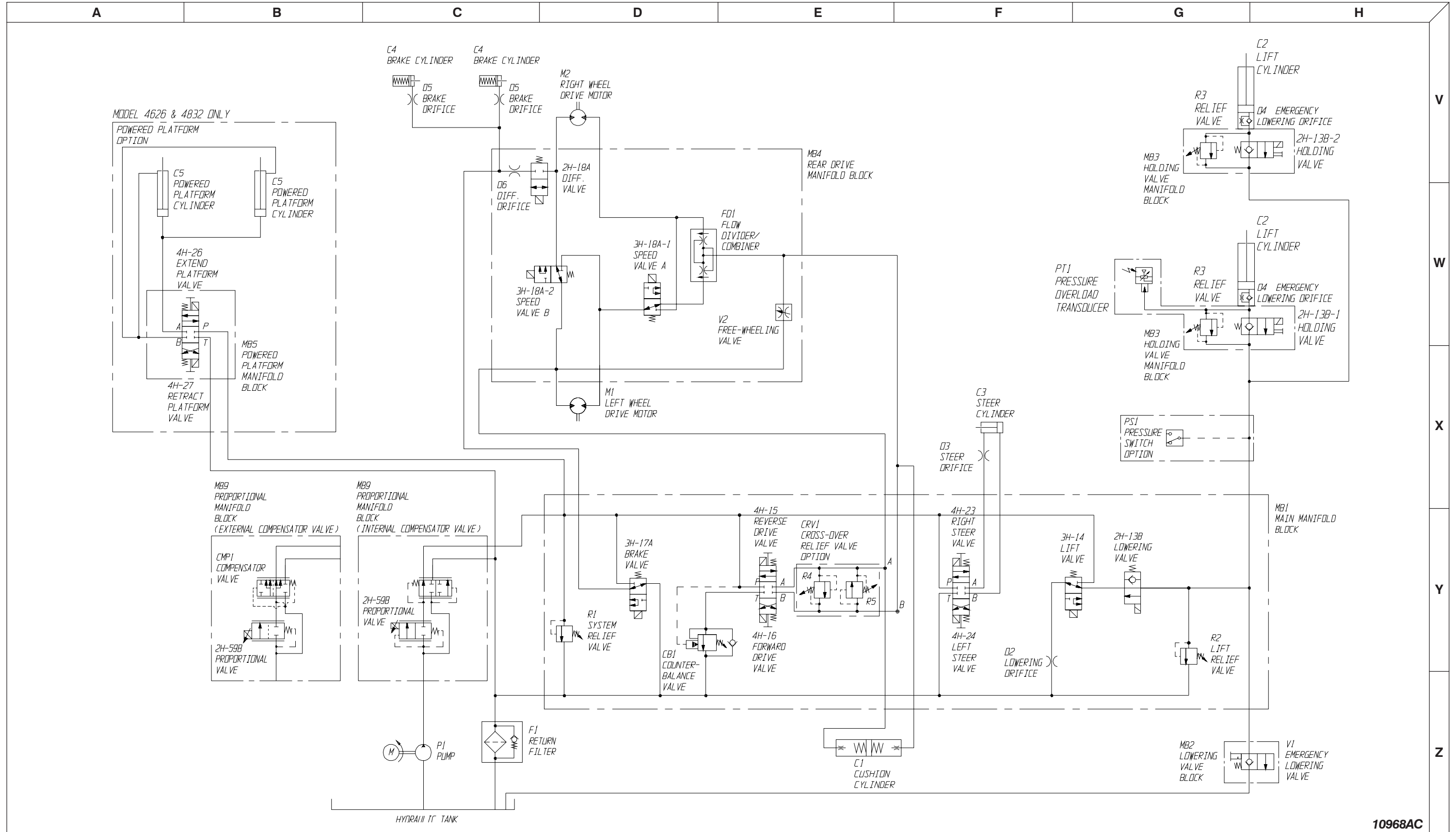
10968AC

Figure 3.3-1. Electrical Schematic and Diagram Parts List

Index No.	Skyjack Part No.	Qty.	Description
AT1	130440	1	TRANSDUCER, Angle
CM1	130439	1	CONTROL MODULE, Integrated Sensor
PT1	134431	1	TRANSDUCER, Pressure 2000 psi (Model 3220M/3226M)
	134532	1	TRANSDUCER, Pressure 1250 psi (Model 3226M)

Figure 3.3-2. Control Module to Transducers Diagram

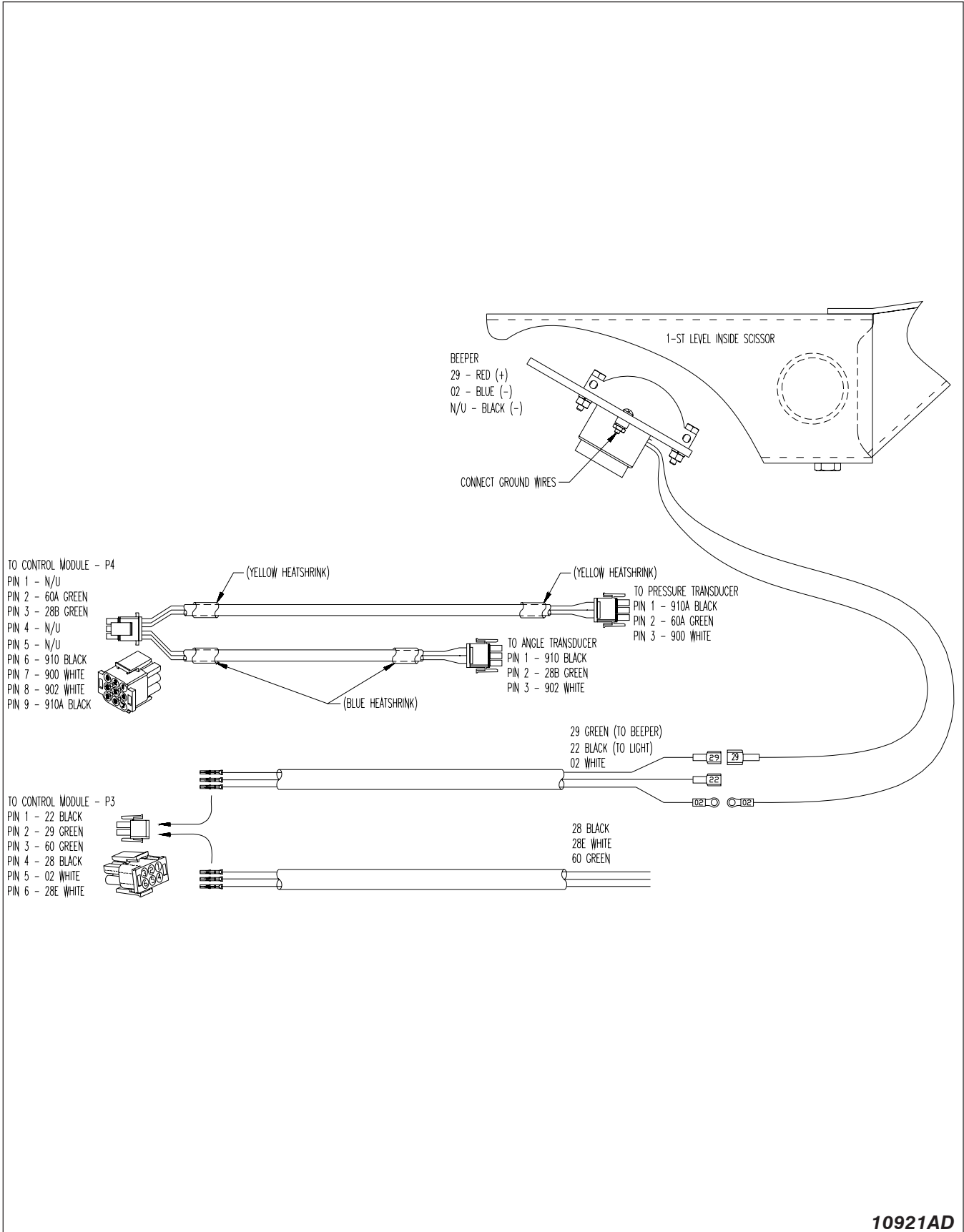

10921AD

Figure 3.3-3. Control Box Wiring Diagram - Equipped With All Options (No rollout limit) - (Model 3220)

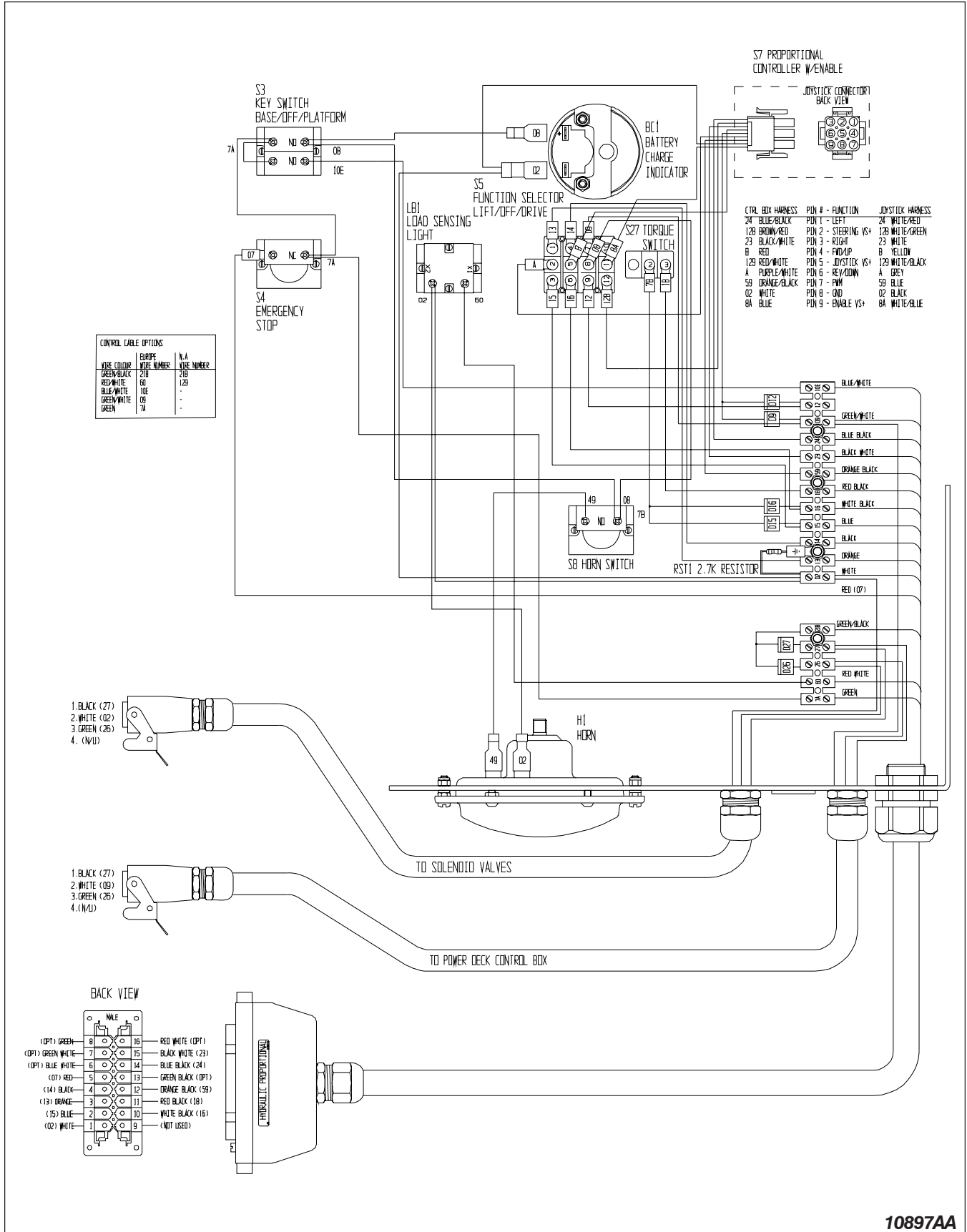

10897AA

Figure 3.3-4. Control Box Wiring Diagram - Equipped With No Option (Model 3226M, 3220M)

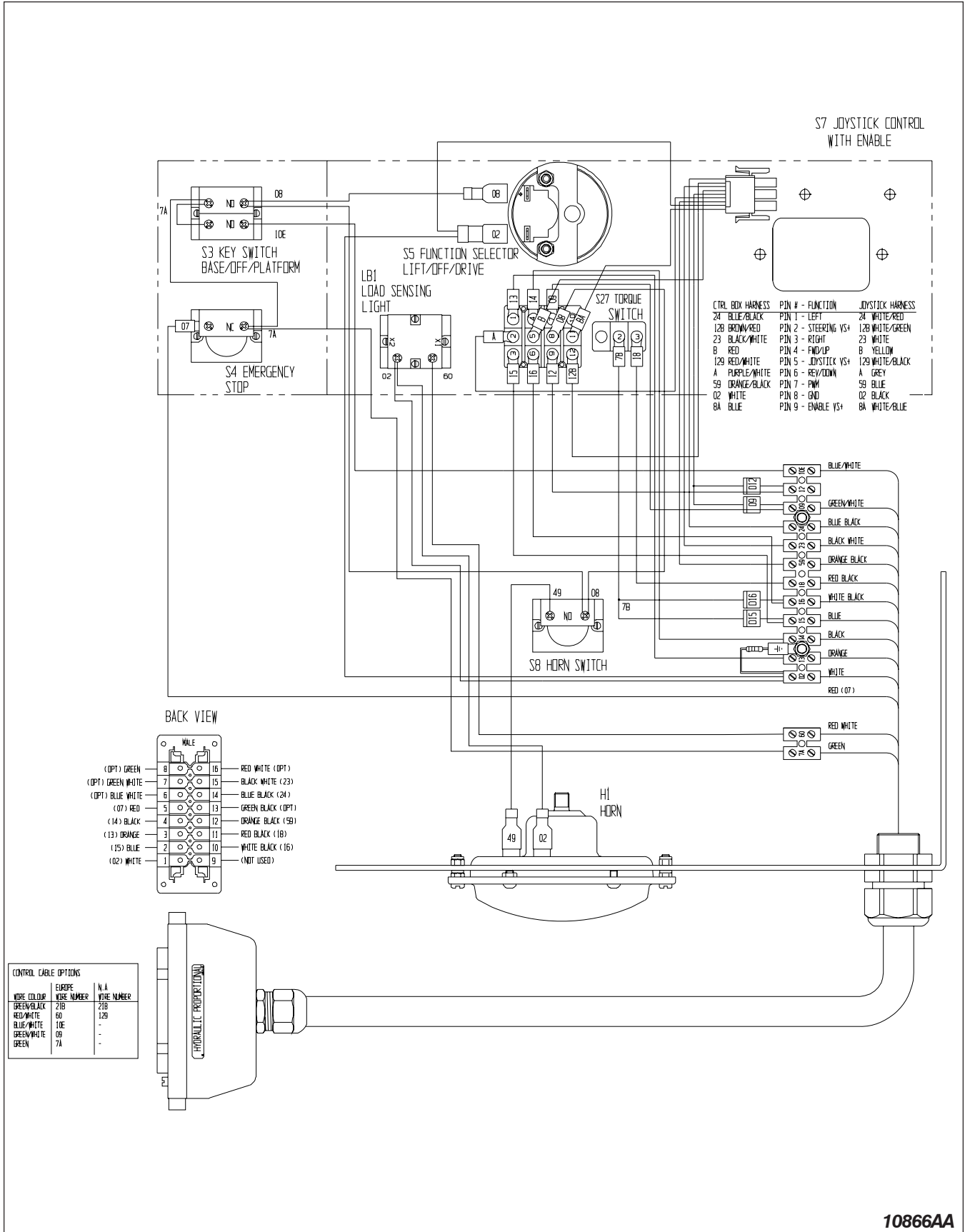

10866AA

Figure 3.3-5. Control Box Wiring Diagram - Equipped With All Option (Model 3226M)

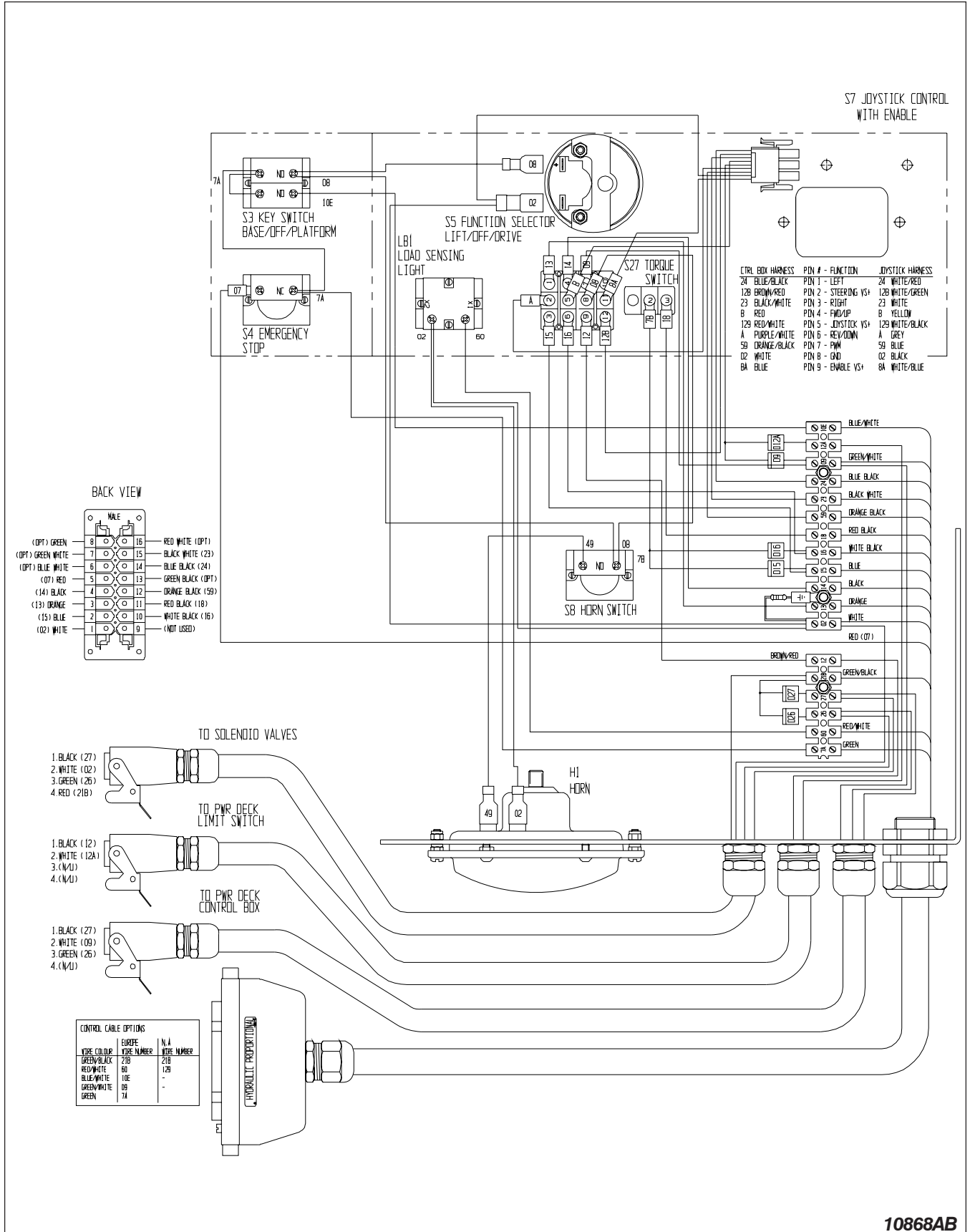

10868AB

Figure 3.5-1. Electrical Schematic - CE Models Equipped With All Options (Model 3220M/3226M)

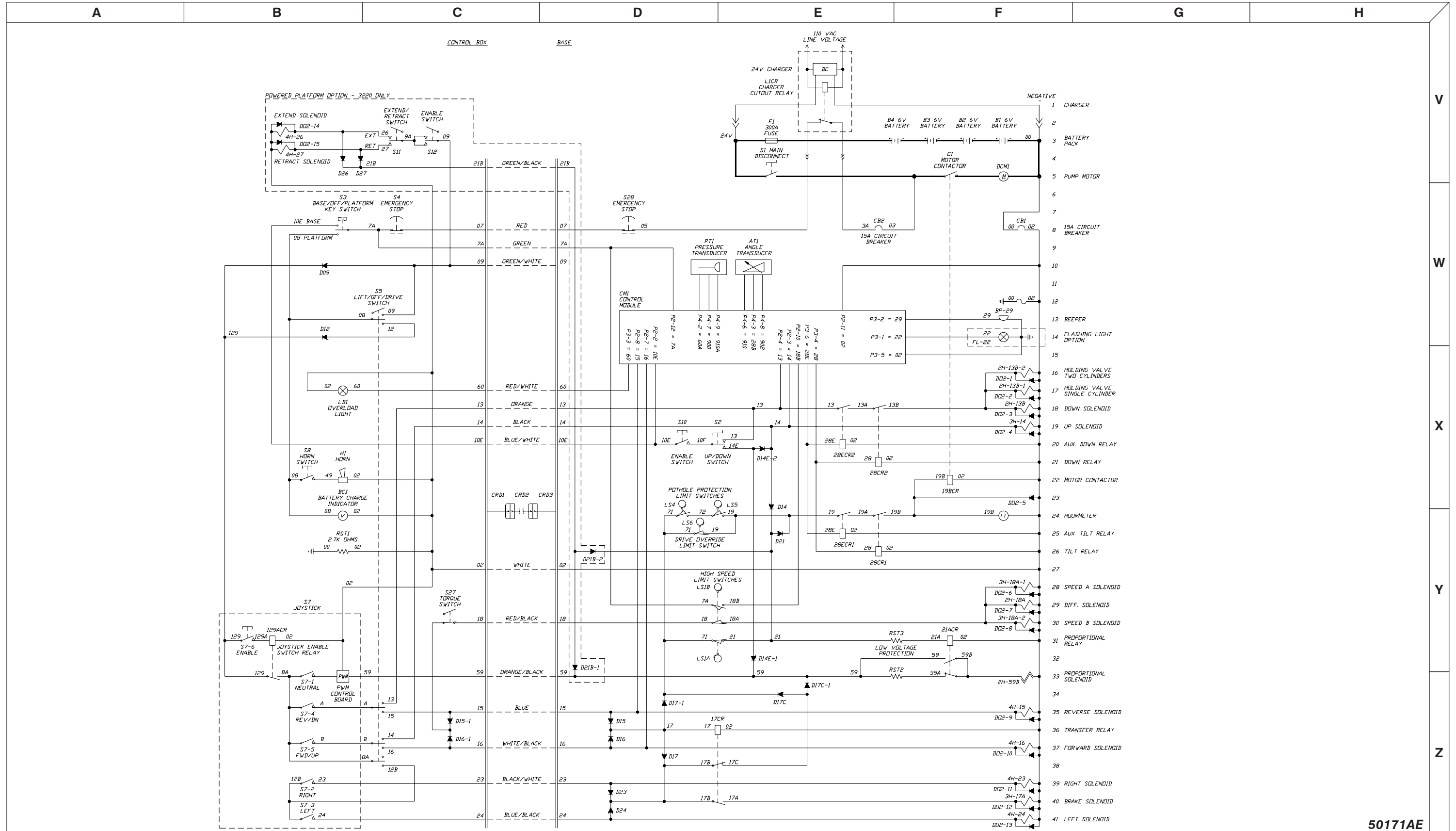

50171AE